



1538 W. Sandalwood Drive,
Lehi, Utah 84043
www.YoungLiving.com

Mandatory Safety

- Never use the product for the proposes other than listed on this manual.
- Read the instruction manual before using this product.
- Remove all packaging before use.
- Use only the power plug contained in the package to avoid damage to the product.
- When unplugging the power adaptor, set your hand on the adaptor body instead of pulling the cord.
- If the unit will not be used for an extended period or needs to be relocated, unplug the AC adaptor, dispose of the water and clean the unit before storage.
- Avoid moving the unit while in use, or carefully holding the whole product with base.
- The precautions listed in this manual are to ensure safe and proper use of this product by the user, and to avoid any danger or loss that might occur to the user or others.
- “WARNING” contains important safety instructions. Be sure to follow these instructions.

Warning

- ⚠️ • This device is not intended for use by persons with reduced physical or cognitive capacities without the necessary experience or knowledge, unless they have been trained to use the device correctly by a person responsible for their safety and have understood the risks involved.
- 🚫 • Stop using the product immediately and unplug the device once smoke, smell, unusual sounds or other anomalies occur.
- 🚫 • Do not modify, fix or dismantle this product, as fire, electric shock or damage may occur.
- ♻️ • When the product is at the end of its life, we recommend disposal at a collection point for the recycling of electrical and electronic equipment, rather than with household waste.



- When this product remains unused for a long period of time, the main unit must be unplugged from the electrical socket and water removed. Otherwise electricshock malfunction may occur.
- This product must be disconnected from the power sources before cleaning and maintenance.
- Please avoid dripping the essential oil onto the exterior of the product or onto furniture. If essential oil dripping accidentally occurs, wipe off immediately to avoid discoloration of the exterior of the product or the furniture.
- This product is not medical equipment. Directly inhaling the aroma mist from the spout is not recommended.



- If you have any special physical conditions, such as pregnancy, lung failure, cancer, epilepsy, or other illnesses, please consult your doctor before using essential oils. Stop using the product and open the windows for ventilation if you start to feel uncomfortable.
- Essential oils are highly concentrated and should always be handled with care, including the amount for each use.
- Do not handle the main unit and outlet with wet hands, or let water or other liquids spill onto them, as this may result in electric shocks.
- This product is not intended for use by persons (including children) with reduced physical, sensory or mental capabilities, or lack of experience and knowledge, unless they have been given supervision or instruction concerning use of the product by a person responsible for their safety.
- Do not let children use this product. Keep out of reach of children as electric shock and injury may occur. Children should be properly supervised to ensure that they will not play with this product.
- To avoid fire, electric shock, injury or damage, do not place the product in the areas listed below:
 - Environments exposed to direct sunlight to high temperatures and keep away from sources of ignition.
 - Pressurized objects and combustibles.

Product Dimensions

Product name: Macaron Ceramic Diffuser
Model code: BL-056
Product size: 156mm(L) x 113mm(H)
Water: Room-temperature tap water/mineral water
Material: Ceramic+PP
Power input: DC24V / 12W
Manufacturer: Bloomy Lotus LLC

Main unit weight: 1080g ± 10 %
Water tank capacity: 290ml
Coverage area: Up to 60m²
Environment: Indoor
Run time: 2/8/16 hours
Made in China

Product Warranty

Thank you for your purchase. The products carry a limited 12-month warranty on manufacturer defects. Please contact your local distributor for after sales enquiries or product maintenance.

Proof of purchase will be required. Warranty does NOT cover:

- Damage of accessories due to often use /depreciation
- Damage due to abuse or improper use of the product
- Damage of non-household use (i.e natural disaster, commercial use)
- Fail to provide any proof of product damage & purchase

We reserves the right for final decision of free product maintenance provided within mentioning period and any other conditions.

Product name : _____ Model no. : _____
Batch no : _____ Point of purchase: _____
Date of purchase: _____



Troubleshooting

If you experienced unsatisfactory operations, please follow our troubleshooting guidelines listed below.

SYMPTOM	POSSIBLE CAUSE	SOLUTION
Diffuser does not turn on/diffuser shuts off before set time is over.	No water in the water tank Power cord not connected correctly	Add water to water tank until it reaches the RED Maximum water marker. Disconnect power cord and re-connect carefully.
No mist or abnormal mist	Normal LED light but no mist.	1. Check the water level. The water level should not be higher than the red water marker. 2. Ensure that tap water or mineral water is added. 3. Defective mist chip, please contact your direct retailer.
	No mist when covered with lid.	1. Avoid placing the product on soft or uneven surfaces. This will block the air inlet at the bottom. 2. Determine if the fan is working. If it is not working, please contact your direct retailer.
	Mist chip with oil residue. Air inlet at the bottom of the diffuser is blocked?	Please follow instructions on cleaning and maintenance. Clean the air inlet. A partially blocked inlet may interfere with the level of mist output.
Water Leak	Temperature and humidity levels can cause the mist to quickly condense into droplets.	Adjust room temperature and humidity levels to compensate.

- Do not attempt to dismantle or repair the product by yourself. If the unit still does not operate satisfactorily, please contact your local distributor.



MACARON DIFFUSER

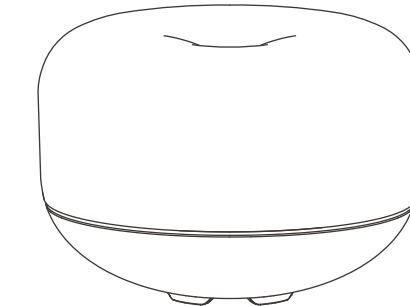

USER'S MANUAL Macaron Ceramic Diffuser

Thank you for purchasing this product.
Please read the user manual carefully before use.

Overview

Main body

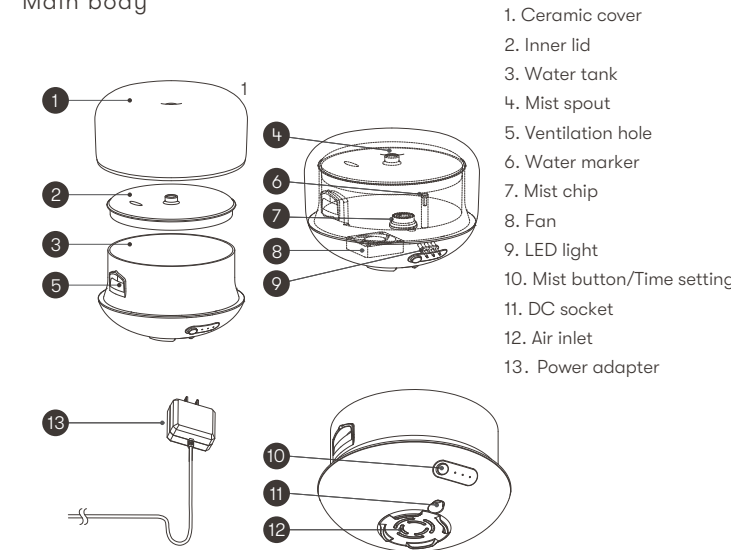

Operating Instructions

- Always place your diffuser on a firm, flat and level surface.

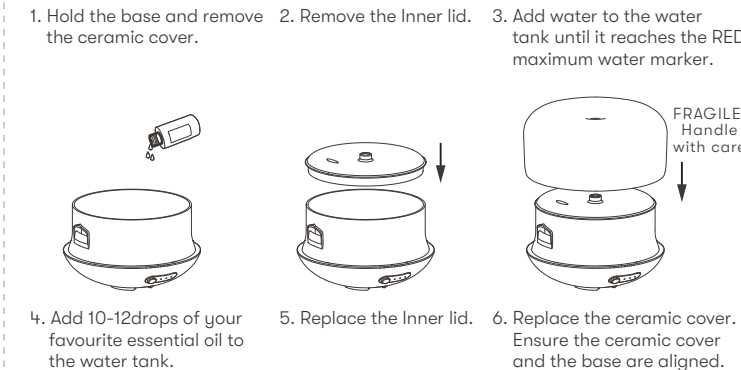
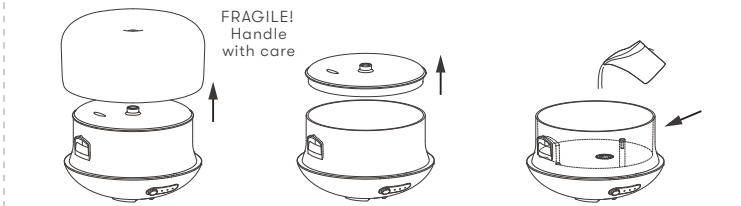

Caution:

1. Be sure to hold the whole product with the base carefully when moving the product. Handle this product with care to avoid impacts or drops.
2. The unit should be placed on a level solid surface. Do not place on carpets, rugs, wooden/polished furniture or unstable surfaces.
3. Use a suitable measuring cup to fill the water into the water tank. Never attempt to fill water under a running tap or whilst plugged in.
4. The water level should not exceed the water marker to avoid damage to this device.
5. Keep water away from Ventilation Hole and Air Inlet.
6. For best result, we recommend to use natural essential oil with this scent diffuser. Artificial fragrance, flavor, or impurities might harm to the unit.
7. Always unplug the product from electrical socket when not in use.
8. Do not remove the cover or lid during operation.

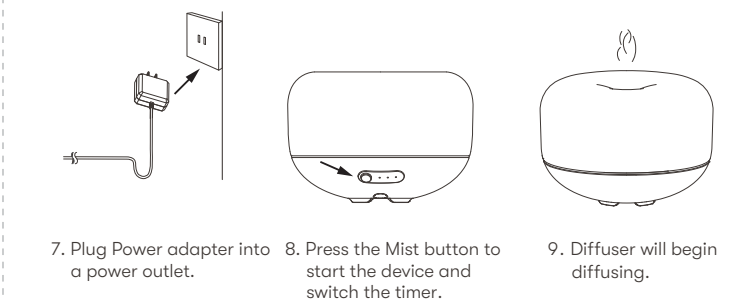

Setting Instructions

Mist

- Press the button once to turn ON the unit. The default time is 2hours, indicated by the 2H LED light.
- Press the button a second time and the working time is set to be 8 hours, indicated by the 8H LED light.
- Press the button a third time and the working time is set to be 16 hours intermittently, indicated by the 16H LED light. (5mins ON and 5mins OFF).
- Press the button a fourth time to switch diffuser OFF.

LED Light

- Once you turn on the diffuser, the candlelight will ON automatically.
- Long press for 2sec to turn off the LED light, long press for another 2sec to turn on the LED light.

Note:

1. A slight difference in mist amount produced by different units is expected.
2. Factors affecting the mist amount: water, humidity, temperature, and air flow.
3. Automatically shut-off function when the diffuser detects the water is empty or when it is tipped over.
4. LED indicator will slightly turn off in 10sec when you selected the mode.

Cleaning and Maintenance

- Always disconnect the AC adaptor from the device before cleaning.

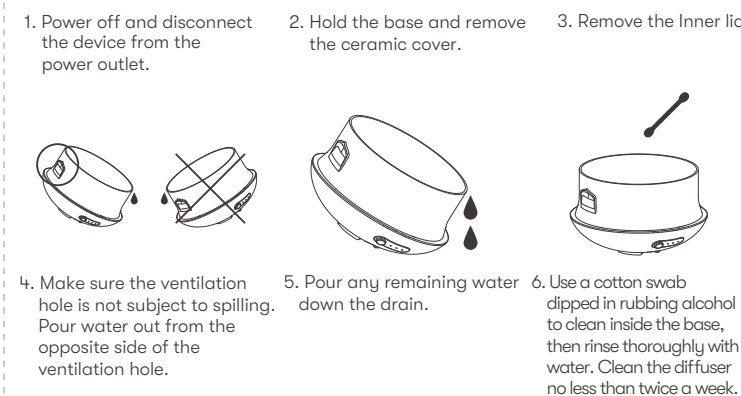
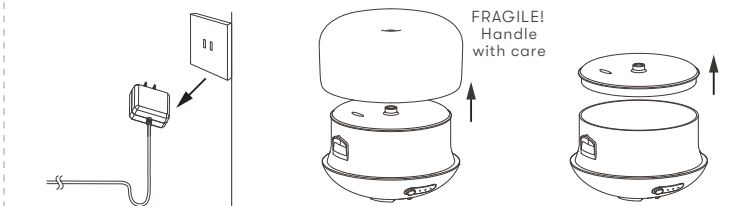

Caution:

- Never soak or wash this product directly as it may cause mechanical malfunction or danger.
- Never use acidic cleansing agents as it may cause malfunctions to the product.
- Use cotton swab to clean the unit after each use. Rinse with tap or spring water, then wipe with a dry cloth.
- The water tank must be cleaned before the essential oil is changed each time.
- Use tap water or spring water.
- Allow to dry thoroughly after use/ cleaning.
- Make sure no water will spit into the air duct outlet as it might break the electrical circuit.